

Problems

- 11.33** An airplane begins its take-off run at A with zero velocity and a constant acceleration a . Knowing that it becomes airborne 30 s later at B and that the distance AB is 900 m, determine (a) the acceleration a (b) the take-off velocity v_B .

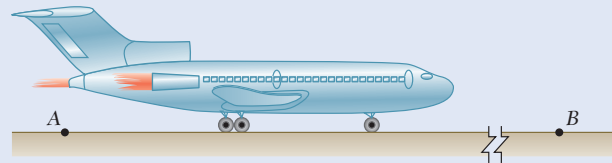

Fig. P11.33

- 11.34** A motorist is traveling at 54 km/h when she observes that a traffic light 240 m ahead of her turns red. The traffic light is timed to stay red for 24 s. If the motorist wishes to pass the light without stopping just as it turns green again, determine (a) the required uniform deceleration of the car, (b) the speed of the car as it passes the light.

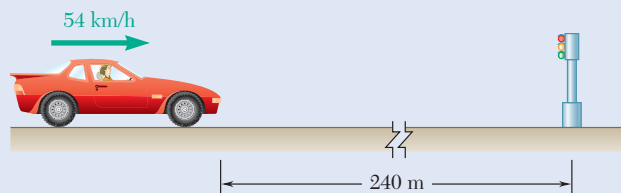

Fig. P11.34

- 11.35** Steep safety ramps are built beside mountain highways to enable vehicles with defective brakes to stop safely. A truck enters a 750-ft ramp at a high speed v_0 and travels 540 ft in 6 s at constant deceleration before its speed is reduced to $v_0/2$. Assuming the same constant deceleration, determine (a) the additional time required for the truck to stop (b) the additional distance traveled by the truck.

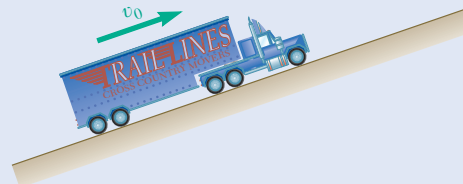

Fig. P11.35

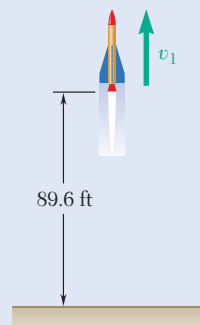

Fig. P11.36

- 11.36** A group of students launches a model rocket in the vertical direction. Based on tracking data, they determine that the altitude of the rocket was 89.6 ft at the end of the powered portion of the flight and that the rocket landed 16 s later. Knowing that the descent parachute failed to deploy so that the rocket fell freely to the ground after reaching its maximum altitude and assuming that $g = 32.2 \text{ ft/s}^2$, determine (a) the speed v_1 of the rocket at the end of powered flight, (b) the maximum altitude reached by the rocket.

- 11.37** A small package is released from rest at A and moves along the skate wheel conveyor $ABCD$. The package has a uniform acceleration of 4.8 m/s^2 as it moves down sections AB and CD , and its velocity is constant between B and C . If the velocity of the package at D is 7.2 m/s , determine (a) the distance d between C and D , (b) the time required for the package to reach D .

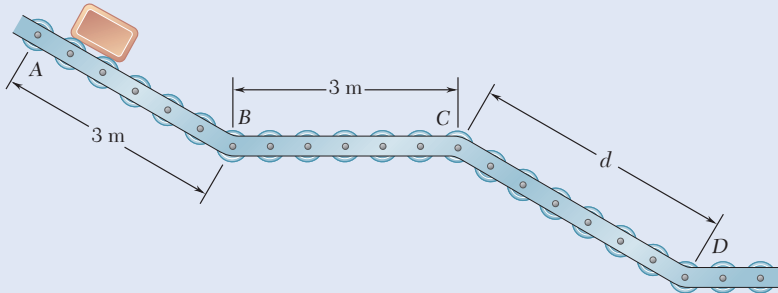

Fig. P11.37

- 11.38** A sprinter in a 100-m race accelerates uniformly for the first 35 m and then runs with constant velocity. If the sprinter's time for the first 35 m is 5.4 s, determine (a) his acceleration, (b) his final velocity, (c) his time for the race.

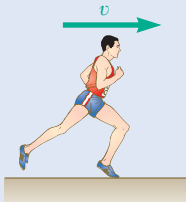

Fig. P11.38

- 11.39** Automobile A starts from O and accelerates at the constant rate of 0.75 m/s^2 . A short time later it is passed by bus B which is traveling in the opposite direction at a constant speed of 6 m/s . Knowing that bus B passes point O 20 s after automobile A started from there, determine when and where the vehicles passed each other.

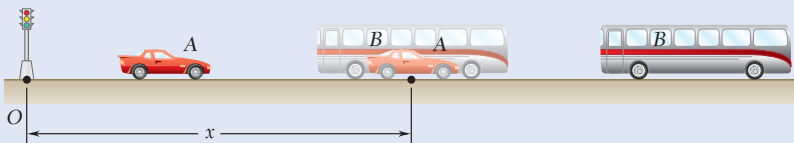

Fig. P11.39

- 11.40** In a boat race, boat A is leading boat B by 50 m and both boats are traveling at a constant speed of 180 km/h . At $t = 0$, the boats accelerate at constant rates. Knowing that when B passes A , $t = 8 \text{ s}$ and $v_A = 225 \text{ km/h}$, determine (a) the acceleration of A , (b) the acceleration of B .

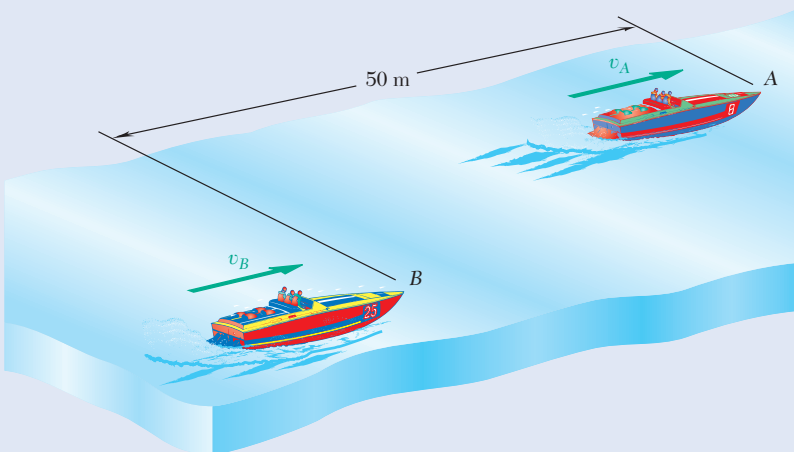

Fig. P11.40

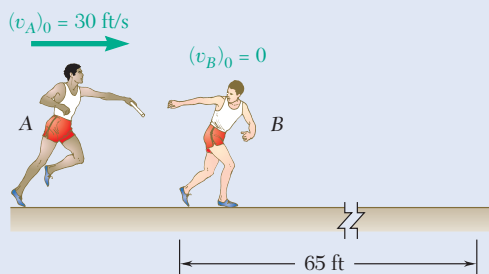

Fig. P11.41

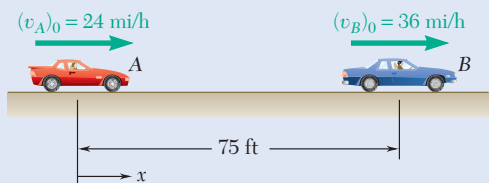

Fig. P11.42

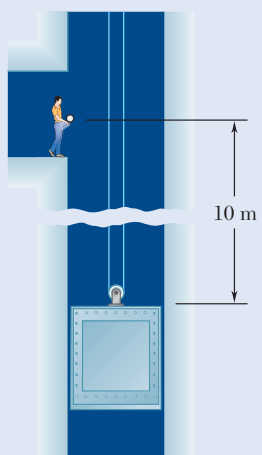

Fig. P11.44

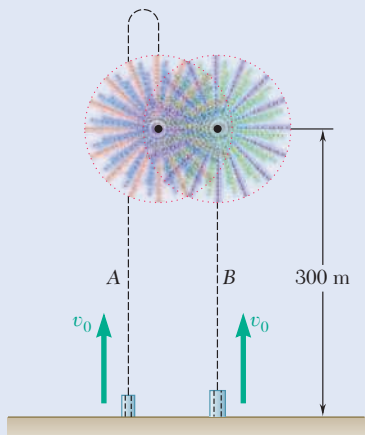

Fig. P11.45

11.41 As relay runner *A* enters the 65-ft-long exchange zone with a speed of 30 ft/s, he begins to slow down. He hands the baton to runner *B* 2.5 s later as they leave the exchange zone with the same velocity. Determine (a) the uniform acceleration of each of the runners, (b) when runner *B* should begin to run.

11.42 Automobiles *A* and *B* are traveling in adjacent highway lanes and at $t = 0$ have the positions and speeds shown. Knowing that automobile *A* has a constant acceleration of 1.8 ft/s^2 and that *B* has a constant deceleration of 1.2 ft/s^2 , determine (a) when and where *A* will overtake *B*, (b) the speed of each automobile at that time.

11.43 Two automobiles *A* and *B* are approaching each other in adjacent highway lanes. At $t = 0$, *A* and *B* are 3200 ft apart, their speeds are $v_A = 65 \text{ mi/h}$ and $v_B = 40 \text{ mi/h}$, and they are at points *P* and *Q*, respectively. Knowing that *A* passes point *Q* 40 s after *B* was there and that *B* passes point *P* 42 s after *A* was there, determine (a) the uniform accelerations of *A* and *B*, (b) when the vehicles pass each other, (c) the speed of *B* at that time.

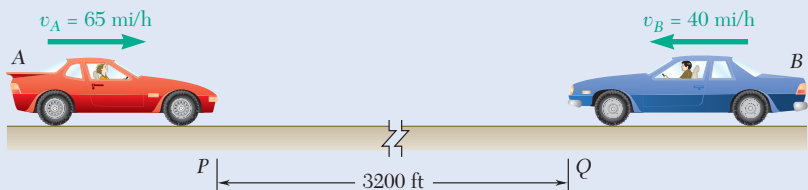

Fig. P11.43

11.44 An elevator is moving upward at a constant speed of 4 m/s. A man standing 10 m above the top of the elevator throws a ball upward with a speed of 3 m/s. Determine (a) when the ball will hit the elevator, (b) where the ball will hit the elevator with respect to the location of the man.

11.45 Two rockets are launched at a fireworks display. Rocket *A* is launched with an initial velocity $v_0 = 100 \text{ m/s}$ and rocket *B* is launched t_1 seconds later with the same initial velocity. The two rockets are timed to explode simultaneously at a height of 300 m as *A* is falling and *B* is rising. Assuming a constant acceleration $g = 9.81 \text{ m/s}^2$, determine (a) the time t_1 , (b) the velocity of *B* relative to *A* at the time of the explosion.

11.46 Car *A* is parked along the northbound lane of a highway, and car *B* is traveling in the southbound lane at a constant speed of 60 mi/h. At $t = 0$, *A* starts and accelerates at a constant rate a_A , while at $t = 5 \text{ s}$, *B* begins to slow down with a constant deceleration of magnitude $a_A/6$. Knowing that when the cars pass each other $x = 294 \text{ ft}$ and $v_A = v_B$, determine (a) the acceleration a_A , (b) when the vehicles pass each other, (c) the distance d between the vehicles at $t = 0$.

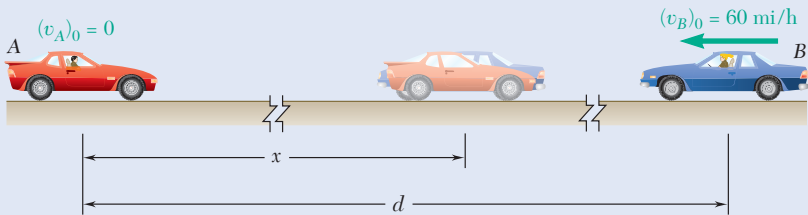

Fig. P11.46

11.47 The elevator E shown in the figure moves downward with a constant velocity of 4 m/s. Determine (a) the velocity of the cable C , (b) the velocity of the counterweight W , (c) the relative velocity of the cable C with respect to the elevator, (d) the relative velocity of the counterweight W with respect to the elevator.

11.48 The elevator E shown starts from rest and moves upward with a constant acceleration. If the counterweight W moves through 30 ft in 5 s, determine (a) the acceleration of the elevator and the cable C , (b) the velocity of the elevator after 5 s.

11.49 An athlete pulls handle A to the left with a constant velocity of 0.5 m/s. Determine (a) the velocity of the weight B , (b) the relative velocity of weight B with respect to the handle A .

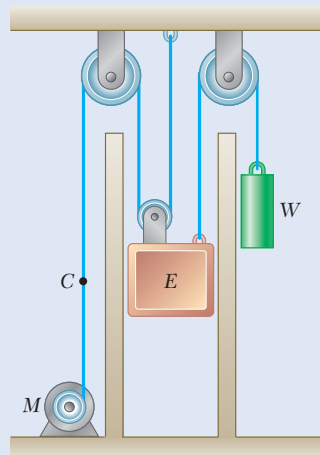

Fig. P11.47 and P11.48

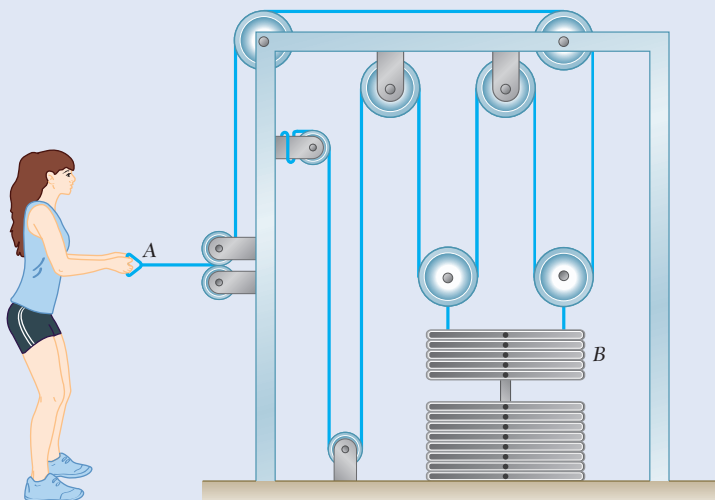

Fig. P11.49

11.50 An athlete pulls handle A to the left with a constant acceleration. Knowing that after the weight B has been lifted 4 in. its velocity is 2 ft/s, determine (a) the accelerations of handle A and weight B , (b) the velocity and change in position of handle A after 0.5 sec.

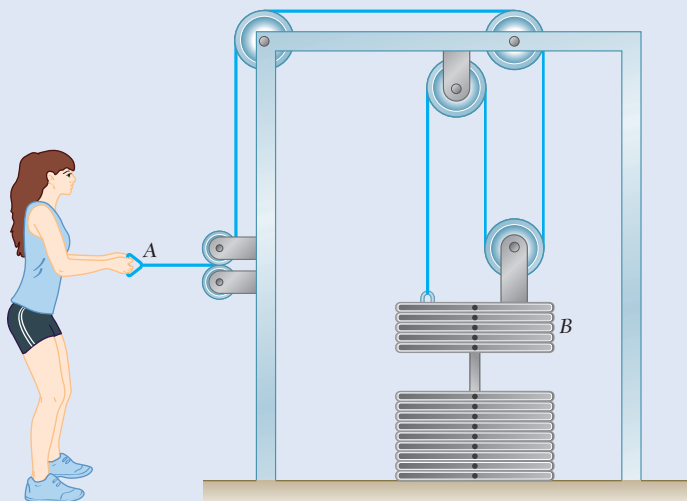

Fig. P11.50

- 11.51** Slider block B moves to the right with a constant velocity of 300 mm/s . Determine (a) the velocity of slider block A , (b) the velocity of portion C of the cable, (c) the velocity of portion D of the cable, (d) the relative velocity of portion C of the cable with respect to slider block A .

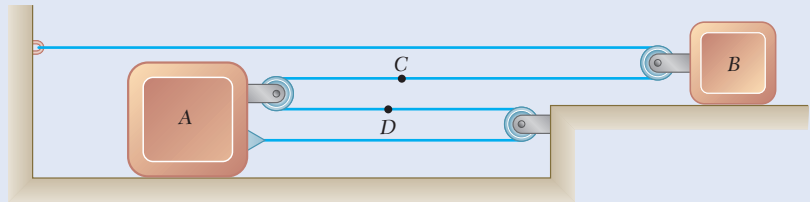

Fig. P11.51 and P11.52

- 11.52** At the instant shown, slider block B is moving with a constant acceleration, and its speed is 150 mm/s . Knowing that after slider block A has moved 240 mm to the right its velocity is 60 mm/s , determine (a) the accelerations of A and B , (b) the acceleration of portion D of the cable, (c) the velocity and the change in position of slider block B after 4 s .

- 11.53** A farmer lifts his hay bales into the top loft of his barn by walking his horse forward with a constant velocity of 1 ft/s . Determine the velocity and acceleration of the hay bale when the horse is 10 ft away from the barn.

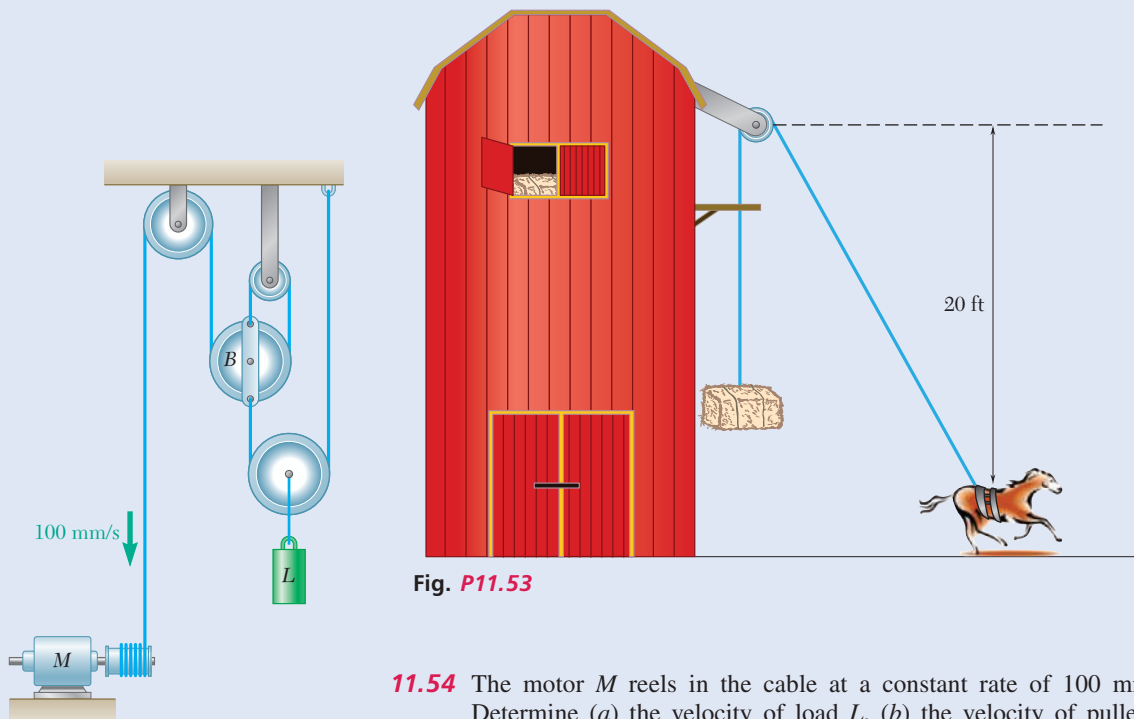

Fig. P11.53

- 11.54** The motor M reels in the cable at a constant rate of 100 mm/s . Determine (a) the velocity of load L , (b) the velocity of pulley B with respect to load L .

Fig. P11.54

- 11.55** Collar *A* starts from rest at $t = 0$ and moves upward with a constant acceleration of 3.6 in./s^2 . Knowing that collar *B* moves downward with a constant velocity of 18 in./s , determine (a) the time at which the velocity of block *C* is zero, (b) the corresponding position of block *C*.
- 11.56** Block *A* starts from rest at $t = 0$ and moves downward with a constant acceleration of 6 in./s^2 . Knowing that block *B* moves up with a constant velocity of 3 in./s , determine (a) the time when the velocity of block *C* is zero, (b) the corresponding position of block *C*.

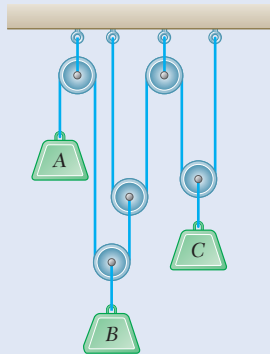

Fig. P11.56

- 11.57** Block *B* starts from rest, block *A* moves with a constant acceleration, and slider block *C* moves to the right with a constant acceleration of 75 mm/s^2 . Knowing that at $t = 2 \text{ s}$ the velocities of *B* and *C* are 480 mm/s downward and 280 mm/s to the right, respectively, determine (a) the accelerations of *A* and *B*, (b) the initial velocities of *A* and *C*, (c) the change in position of slider block *C* after 3 s .
- 11.58** Block *B* moves downward with a constant velocity of 20 mm/s . At $t = 0$, block *A* is moving upward with a constant acceleration, and its velocity is 30 mm/s . Knowing that at $t = 3 \text{ s}$ slider block *C* has moved 57 mm to the right, determine (a) the velocity of slider block *C* at $t = 0$, (b) the accelerations of *A* and *C*, (c) the change in position of block *A* after 5 s .
- 11.59** The system shown starts from rest, and each component moves with a constant acceleration. If the relative acceleration of block *C* with respect to collar *B* is 60 mm/s^2 upward and the relative acceleration of block *D* with respect to block *A* is 110 mm/s^2 downward, determine (a) the velocity of block *C* after 3 s , (b) the change in position of block *D* after 5 s .
- *11.60** The system shown starts from rest, and the length of the upper cord is adjusted so that *A*, *B*, and *C* are initially at the same level. Each component moves with a constant acceleration, and after 2 s the relative change in position of block *C* with respect to block *A* is 280 mm upward. Knowing that when the relative velocity of collar *B* with respect to block *A* is 80 mm/s downward, the displacements of *A* and *B* are 160 mm downward and 320 mm downward, respectively, determine (a) the accelerations of *A* and *B* if $a_B > 10 \text{ mm/s}^2$, (b) the change in position of block *D* when the velocity of block *C* is 600 mm/s upward.

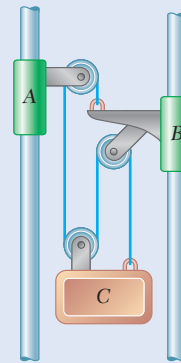

Fig. P11.55

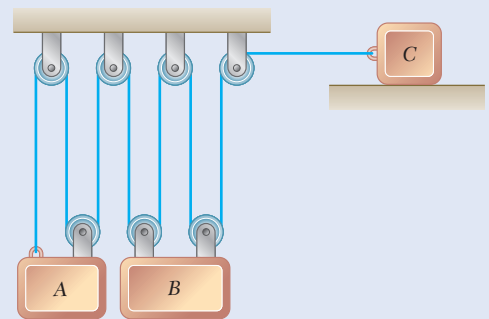

Fig. P11.57 and P11.58

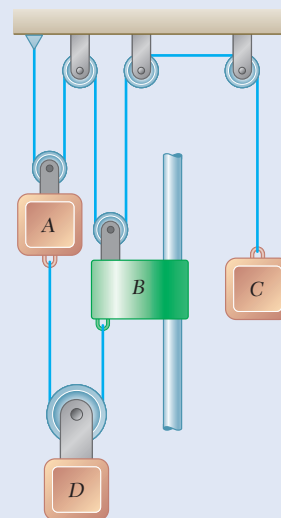

Fig. P11.59 and P11.60